



NEPI Working Paper

Small Modular Reactors: Costs, Waste and Safety Benefits

Geoffrey Rothwell, Ph.D.
Department of Economics
Stanford University

December 17, 2012

Small Modular Reactors: Costs, Waste, and Safety Benefits

Geoffrey Rothwell, Ph.D.
Department of Economics, Stanford University
Stanford, California, U.S.A.
rothwell@stanford.edu

December 17, 2012

Abstract

After many years without nuclear power plant construction, five nuclear power plants are being built in the U.S.: Tennessee Valley Authority is completing Watts Bar Unit 2, Georgia Power is building Vogtle Units 3 and 4, and South Carolina Electric & Gas is building Summer Units 2 and 3. While there are 10 other applications for construction and operating permits, the construction cost for advanced nuclear power presents a barrier to finishing these units. These costs reflect a redesign of nuclear power plants to rely on natural safety systems, also known as passive safety. While these are better than our father's nuclear power plants, in deregulated markets, the electric utilities must shoulder the entire risk of building and operating them. This makes Wall Street edgy, increasing the risk premium on anything nuclear. However, one thing about nuclear power is that while the up-front costs are large, the operating costs are relatively low, exactly the opposite of combined-cycle natural gas generation with low upfront costs, but very volatile operating costs. Combining them minimizes the weighted risk-adjusted levelized cost of electricity. However, building nuclear plants hinges on the cost of capital available to nuclear investors. One way to lower that cost is by completing the plants under construction on time and on budget. Another way to lower the cost of capital is to lower the size of upfront costs required to add a nuclear plant to a portfolio of generating assets. Small Modular Reactors, SMRs, can provide nuclear power at a lower initial investment. All SMRs being considered for near-term development in the U.S. (but not in other countries) are passively safe, e.g., after the Babcock & Wilcox mPower reactor shuts itself off, because of its underground design, the reactor's heat dissipates into the earth surrounding it. The U.S. nuclear navy has been safely using small Light Water Reactors for almost 60 years. Deploying a new technology also allows the formation of a new system for handling used nuclear fuel. If Congress is able to remove the requirement that licensing interim used nuclear fuel facilities depends on licensing a geologic repository, electric utility owned interim storage facilities can provide storage to the year 2222 for less than electric utilities' contributions to the Nuclear Waste Trust Fund. Large and small passively safe nuclear power plants deserve development funds to provide a base-load zero-carbon alternative a mix of generating assets including intermittent renewables.

Acknowledgements: This paper is based on a series of lectures by Geoffrey Rothwell written for the National Energy Policy Institute, NEPI, with funding from the George Kaiser Family Foundation. I thank Mary Haddican and Tony Knowles for their comments, careful reading, and encouragement. These pages reflect the author's views and conclusions, and not those of any other organization or individual, including NEPI and Stanford University.

Executive Summary

Most of the world's new nuclear power plants are being built in the "CRISK" countries of China (26 units), Russia (9 units), India (7 units), and South Korea (5 units). In the U.S., five units are under construction with the completion of Watts Bar Unit 2 by the Tennessee Valley Authority, TVA, and the construction of four new Westinghouse AP-1000s in Georgia and South Carolina. The major impediment to new nuclear construction in the U.S. is the cost of capital available from Wall Street, in part, reflecting the risk of any new technology, but also reflecting the financial size of a new nuclear power plant in comparison to the financial size of the average U.S. electric utility. If the cost of finance capital is high, so will be the long-run average cost, or the levelized cost of electricity of nuclear power.

Wall Street investors remember when the industry discovered it was in regulatory quicksand after the accident at Three Mile Island, Unit 2 (TMI), in March 1979. Resulting U.S. Nuclear Regulatory Commission licensing delays led to dozens of nuclear power plant cancellations and the largest default on government bonds in U.S. history. In 1983, the Washington Public Power Supply System, WPPSS, pronounced "whoops," defaulted on \$2.25 billion (\$4.5B in 2011\$) in bonds to finance 5 nuclear power plants in hydro-rich Washington state. Without government backing, the U.S. nuclear power industry cannot compete nationally with unsustainably cheap natural gas and internationally with foreign corporations and government companies with access to cheap finance capital.

In response to these licensing delays, the U.S. Nuclear Regulatory Commission, NRC, is in the process of implementing a new licensing system (10 CFR Part 52), with three parts:

- (1) "Design Certifications" of standardized nuclear designs;
- (2) "Early Site Permits," for sites that met the environmental standards required for the construction of a standardized nuclear design; and
- (3) "Combined Construction and Operating Licenses," for nuclear power plants built to the standards of the design certification and site permits.

These regulatory changes were intended to reduce the regulatory risk of constructing new nuclear by decoupling the design and site licensing process from the operating license, thus, avoiding the hijacking of the old regulatory process by any number of stakeholders.

If the new regulatory system can insure against licensing delays, for new nuclear power to develop either electric utilities could merge into larger entities, or smaller nuclear power plants are required to reduce the risk premium on nuclear technology. To this end, U.S. Department of Energy, DOE, is facilitating the development of Small Modular Reactors to provide a safe non-carbon alternative to fossil fuel and aging nuclear power plants worldwide. Section 1 discusses the status of the U.S. and international nuclear power industries. Section 2 discusses the costs of new nuclear power in the U.S.

On the other hand, as Senator Feinstein has been asking, "Why fund the development of a new nuclear reactor system while the NRC has no confidence that the DOE will be able to take ownership of fuel rods in at-reactor storage facilities?" NRC Chair Macfarlane has noted that the NRC staff is continuing to review licenses while the Commission discusses the problems posed

by the DOE's cancellation of the Yucca Mountain waste repository. Fortunately, a simple solution exists: Congress can vote to repeal the *one sentence* of the U.S. Code that prohibits the consideration of interim storage facilities until a geologic repository is licensed. Congress must step up to the plate, and hit the "waste confidence issue" out of U.S. energy policy field. Section 3 discusses the nuclear fuel cycle and the problem of managing used nuclear fuel.

Section 4 discusses the accidents at Three Mile Island, Chernobyl, and Fukushima. A review of these accidents leads one to emphasize the importance of introducing *passive* safety systems that reduce human intervention, and creating *active* nuclear safety regulators that intervene sufficiently when necessary. Three rules summarize these lessons:

- (1) A passively safe plant is more reliable than an actively safe plant at the same cost per kilowatt.
- (2) A safer plant is more productive and profitable than a safe plant.
- (3) A safer industry with an active regulator is more successful than a safe industry with a passive regulator.

Following these rules, bi-partisan Congressional policy makers should increase funding for an early deployment of passively safe Small Modular Reactors, based on U.S. nuclear navy logistics, and the unparalleled success and safe operation of Small Light Water Reactors, SLWRs, in nuclear submarines and aircraft carriers. The primary showstopper in the U.S. for new nuclear power is its cost. Section 5 discusses what the Congress can do to help Americans compete with the Chinese in the international nuclear power industry before the Chinese nuclear power industry and policy becomes more important internationally than the U.S. nuclear power industry and policy.

Section 1: The Status of the Nuclear Power Industry

Until the 1980s, the U.S. nuclear power industry dominated international nuclear power reactor and nuclear fuel markets with the Westinghouse Pressurized Water Reactor, PWR, and the General Electric (GE) Boiling Water Reactor, BWR. On the other side of the world, the Soviet Union built almost five dozen Pressurized Water Reactors, VVERs, and almost two dozen RBMKs, a Light Water Graphite Reactor that produces both plutonium and electricity, for example, at Chernobyl. (The U.S. built a similar reactor, the N-Reactor, outside Richland, Washington, and operated it from 1965 until the Chernobyl accident in April 1986.)

Two other U.S. nuclear steam supply system, NSSS, manufacturers, Combustion Engineering and Babcock & Wilcox, also competed in the PWR market. Combustion Engineering built 14 nuclear power units, the largest plant being Palo Verde in Arizona with three units and a combined total of almost 4,000 megawatts-electric, MW. The U.S. Nuclear Regulatory Commission, NRC, certified their standardized design, the System 80+, in May 1997. Although the System 80+ was not built, it became the foundation of South Korea's Next Generation Reactor, now known as the Advanced Power Reactor, APR-1400, which is under construction in South Korea and the United Arab Emirates. Babcock & Wilcox, B&W, after having built ten PWRs, suffered a serious setback with the accident at Three Mile Island, TMI, Unit 2, in March 1979; see Section 4.

After March 1979, a malaise infiltrated the U.S. nuclear power industry until the completion of Watts Bar Unit 1 in 1996, signaling a new beginning of nuclear power. Since then, DOE has initiated various programs to reenergize the U.S. nuclear power industry. In 2000, it started the NP2010 program with the goal of operating a new nuclear power plant in the U.S. by 2010. Although it did not start by 2010, the TVA has restarted the construction of Watts Bar Unit 2 under the old regulatory codes (10 CFR Part 50).

Table 1: Construction and Site Preparation Starts (2012)

Plant name	Type	Size	Date On-line
Watts Bar 2	1 PWR	1.2 GW	2015
Vogtle 3 & 4	2 AP1000a	2.2 GW	2016+2017
Summer 2 & 3	2 AP1000a	2.2 GW	2017+2018
Bellefonte 1	1 PWR	1.2 GW	2019
Turkey Point 6 & 7	2 AP1000a	2.2 GW	2022+2023
Levy 1 & 2	2 AP1000a	2.2 GW	2024+2026
Total	10 units	11.2 GW	2015-2026

To encourage the emergence of new nuclear power technologies, Congress passed the *Energy Policy Act of 2005* to facilitate the construction of First-of-a-Kind, FOAK, nuclear plants. It included three provisions:

- (1) Production Tax Credits of \$18/MWh for 8 years to the first 6,000 MW of new nuclear power capacity built by 2021;
- (2) Standby Support to pay for delays due to licensing procedures; and
- (3) Loan Guarantees to pay for loans on which nuclear construction should it default.

In 2007, Congress appropriated \$18.5 billion dollars for loan guarantees. DOE provisionally offered a loan guarantee for Vogtle (although the terms of the loan guarantee have not yet been finalized). According to the White House's Office of the Press Secretary (February 16, 2010),

“Underscoring his Administration’s commitment to jumpstarting the nation’s nuclear generation industry, President Obama today announced that the Department of Energy has offered conditional commitments for a total of \$8.33 billion in loan guarantees for the construction and operation of two new nuclear reactors at a plant in Burke, Georgia [Vogtle].”¹

1. In a White House Briefing to discuss this press release, Press Secretary Gibbs, answered a question posed as to why the Obama Administration was no longer considering funding DOE’s license for Yucca Mountain, “Well, look, I think what has taken Yucca Mountain off the table in terms of a long-term solution for a repository for our nuclear waste is the science. The science ought to make these decisions. The President has a panel headed by Lee Hamilton and Brent Scowcroft, two very able individuals, to help decide a problem that, as you mentioned –I think it was the– I think the *Nuclear Policy Act of 1986* is what began the process of collecting money to build a long-term nuclear waste repository. . . The President believed throughout the campaign, and said as much, that we need a balanced approach. He made good on that balanced approach today. We increased the loan guarantees in the

Unfortunately, the Loan Guarantees have not been as generous as expected after the passage of the *Energy Policy Act of 2005*. First, Congress must appropriate specific funds equal to the loan to be guaranteed. Second, DOE charges a fee equal to what Wall Street would charge on a Credit Default Swap for a similar guarantee. Therefore, nuclear investors cannot apply for Loan Guarantees unless a budget-cutting Congress appropriates the *amount of the loan, and they must pay* for the guarantee at the rate Wall Street would charge, if Wall Street would invest in new nuclear power. These two blades of a public finance scissor have cut the muscle from the DOE's Loan Guarantee program.

However, in response to this perceived stimulus, Westinghouse is building four NRC certified (in December 2011) Advanced Passive 1,000 MW PWR, the AP-1000a (amended), at two sites in the U.S.: Vogtle in Georgia being built by Georgia Power, a division of Southern Company, and Summer in South Carolina being built by South Carolina Electric & Gas, a part of SCANA. See Table 1. Westinghouse is building four AP-1000 (the NRC approved the design in January 2006) at two sites in China: Sanmen, and Haiyang; as well as completing the Westinghouse PWR at Watts Bar Unit 2.

GE is partnering with Hitachi on all commercial nuclear activities, creating General Electric Hitachi, GEH, which is completing the construction of the Advanced BWR, ABWR (licensed by the NRC in August 1997) at the Lungmen site in Taiwan and hopes to finish construction of Shumane Unit 3 and Ohma Unit 1 in Japan. GEH is also building a laser-based uranium enrichment plant in the U.S., possibly at Paducah, Kentucky, to enrich the billion tons of uranium hexafluoride, UF₆, tails accumulated by the AEC, the DOE, and the U.S. Enrichment Corporation, USEC.

In addition, in 2011, Congress appropriated funds to develop a Small Modular Reactor, SMR, based on U.S. naval reactor logistics. B&W has been selected by DOE (November 2012) for support of First-of-a-Kind Engineering, FOAKE, and NRC design certification of its mPower plant, a 180 MW underground, passively-safe PWR with an integrated reactor and steam generator. The TVA with Bechtel could build up to six units at its Clinch River site near Oak Ridge, Tennessee.

Although this history hints at the global flavor of the nuclear power industry, one should recognize that the nuclear power industry is very international: Toshiba (formerly, Tokyo Shibaura Electric) owns 87% of Westinghouse (based in Pittsburg, Pennsylvania) and Kazakhstan (through Kazatomprom, which produced about 36% of the world's uranium mined in 2011) owns 10% of Westinghouse. France's AREVA owns nuclear fuel fabrication facilities in the U.S., and the NRC has approved AREVA building an enrichment facility in Idaho using European-Union-based Urenco centrifuges. They will be competing with Urenco's own new enrichment facility in New Mexico that began operation in July 2011 (which it would like to

federal –in our current federal budget deficit to build more of these facilities to strike that balance and also to create– begin to create a market for cleaner energy sources through comprehensive energy legislation.” <http://www.whitehouse.gov/the-press-office/briefing-white-house-press-secretary-robert-gibbs-21610>

increase to 10 million Separative Work Units, SWU, of annual enriching capacity; on enrichment, see Section 3).

In September 2012, the NRC granted a license to GEH to build 6 million SWU of annual enriching capacity through Global Laser Enrichment, GLE (24% of which is owned by Cameco, which produced about 16% of the world's uranium in 2011). Normally, this would be enough enrichment capacity to satisfy the annual requirements of 60 nuclear reactors, however, if GLE uses (free and depleted) UF_6 tails, much less than 60 plants could be supplied. With Russia's huge enrichment capacity coming into international markets, there could be a glut of enrichment services until the CRISK reactors under construction and in planning come into operation.

While the U.S. nuclear power sector is slowly moving forward, given that the industry is international in scope, its future in the U.S. does not depend exclusively on what happens in the U.S. The U.S. lost its ability to direct the Western international industry in the 1980s to France and Japan, as France built up its successful nuclear power and nuclear fuel operations, and Japan coordinated the construction of 55 nuclear power reactors, but suffered a series of accidents in the nuclear fuel cycle programs. French nuclear joint-stock companies are now languishing with the absence of orders for its 1,660-MW European Pressurized Reactor, EPR, and the French are reconsidering their dependence on nuclear power after the accident at Fukushima, in which Tokyo Electric Power's, TEPCO's, management exposed contradictions built into the Japanese nuclear power industry over the last four decades; see Section 4.

On the other hand, South Korea and the state-owned nuclear power industries of Russia and China are moving to dominate new nuclear power. South Korea built seven nuclear reactors between 2002 and 2012, five more Korean-designed units are under construction in South Korea, and two are under construction in the United Arab Emirates. On July 4, 2012, the Korean Nuclear Safety and Security Commission certified SMART, the System-integrated Modular Advanced Reactor, a 100-MW unit, which South Korea hopes to export to the islands and peninsulas of the southern seas of Asia where energy resources and transmission capacity are scarce, and electricity is expensive.

Russia announced in November 2012, that it would accelerate nuclear power industry investment to develop technologies that it had been considering for commercialization in 2030 by 2020. In 2010, Russia began constructing a ship-based small reactor, the KLT-40S, which it hopes to operate by the end of 2013, and will deploy in ports opening on the Arctic Ocean as the northern sea ice recedes.

China built 12 nuclear power units between 2002 and 2012, and 26 more are under construction, 20 of which use a Chinese 1,000-MW PWR design. (Chinese construction slowed after the accident at Fukushima, but it is back on track to achieve its 5-year plan targets; however, the bullet train crash and the covering up of evidence in July 2011 could lead to reluctance by the Chinese public to support exponential expansion of Chinese nuclear capacity without an equal expansive embrace of a culture of nuclear safety.) In April 2011, China began constructing a two-unit, 210 MW gas-cooled reactor with a single steam generator, the High-Temperature Reactor-Pebble Bed Modular, HTR-PM, which it hopes to scale up to a six-unit plant capable of producing 660 MW with a thermal efficiency of 44%, one-third greater than the 33% at large light water nuclear power plants.

Therefore, one must evaluate the nuclear power industry in its international setting and refrain from focusing on the nuclear power activities of a single country. Whether there has been a “nuclear power renaissance” in the U.S. is moot if there has been a global nuclear power re-birth, as there has been in CRISK countries. The U.S. nuclear power industry does not have the same global importance that it once had.

To recover U.S. competitiveness in nuclear plant manufacturing, DOE has selected B&W’s mPower design for cost-sharing development, and DOE could select another design among the three others that applied for federal development support: Westinghouse’s W-SMR, NuScale Power’s NuScale, and Holtec’s HI-SMUR. All designs are passively safe, like Westinghouse’s AP-1000. While the cost per kilowatt will be higher for smaller nuclear power plants, the levelized cost could be equal or less than the larger plants because the financial costs could be lower for plants that represent a smaller portion of an electric utility’s assets. Moody’s has consistently downgraded the bonds of any utility that builds a nuclear power plant. Moody’s (2011) wrote (updating Moody’s 2007, 2008, and 2009),

“Today’s downgrade of SCE&G’s senior unsecured and Issuer Rating to Baa2 considers the heightened risk associated with a large nuclear construction program extending through 2019 that is expected to be about 50% debt financed and will pressure future financial metrics. In general, Moody’s expects that utilities embarking on a nuclear construction cycle will have financial metrics that are robust for their rating category. In our view, SCE&G’s financial metrics meet that criterion for a Baa2 rating, but not for a Baa1 rating. Moody’s rating also takes into account a credit-supportive regulatory regime. South Carolina legislation that incentivizes nuclear construction and very manageable environmental compliance requirements, which is balanced against the *extreme asset concentration* that the Summer station will represent upon completion. SCE&G’s first mortgage bond rating of A3 reflects Moody’s typical two notch uplift for senior secured obligations of regulated utilities with stable outlooks.” (*emphasis added*)

In addition, SMRs could involve privately owned centralized used fuel storage facilities, solving the “waste confidence” issue born with the cancellation of the Yucca Mountain repository. This paper begins by disentangling the costs of plants under construction in the U.S. It then tackles the waste confidence issue by discussing the possibility of constructing a Monitored Retrievable Storage facility similar to the one licensed by the NRC in February 2006. After discussing nuclear plant safety in the context of the accidents at TMI, Chernobyl, and Fukushima, the paper summarizes the competitive advantages of the SMR. If SMR development is successful, the U.S. might have new a central-station alternative to replace obsolete fossil-fired power plants, plants that produce billions of tonnes of carbon dioxide, which could be warming the Arctic Ocean, necessitating the deployment of ship-based reactors along Russia’s 40% of the Arctic Circle. The last section explores the deployment of large and small passively-safe Light Water Reactors, LWRs, to satisfy clean air standards.

Section 2: The Costs of New Nuclear Power

Although other issues are important in the U.S., they do not have the show stopping power of the “cost issue.” While there is some federal government involvement in the U.S. nuclear power industry, for example, through DOE programs and the TVA, in many countries

the nuclear power industry is directly or indirectly supported, by, or is a part of, the government. This reason for this is the dual nature of nuclear technologies, particularly enrichment, reactor, and reprocessing technologies, which can be used for either civilian or military purposes. To minimize technology leaks, some governments retain ownership of the nuclear sector, as the U.S. did with the Atomic Energy Commission, AEC, until the Ford Administration split the AEC into the NRC (on January 19, 1975), and what was to become DOE. For example, in France, the French government consolidated the French nuclear power industry around the PWR and enriched uranium in 1974. It has been promoting the nuclear power industry in many ways since, including the creation of a nuclear power conglomerate joint-stock company, AREVA, and the operation of almost 60 nuclear power reactors by another government joint-stock company, Electricité de France, EdF.

Russia inherited much of the infrastructure of the Soviet nuclear power industry (but not the huge uranium mining capability of Kazakhstan). Although the Russian nuclear power industry has been under continuous reorganization since the collapse of the Soviet Union, the industry has managed to avoid wholesale privatization and sub-division. This implies that nuclear industrial facilities must rely on Moscow. It also implies that it has access to Russian government resources, to complete, for example, the Bushehr VVER in Iran, or provide loans and education programs to build VVERs in Turkey. Therefore, the U.S. nuclear power industry must compete against firms with much greater access to their governments' resources. This uneven access to governmental resources acutely affects the cost of capital available to the builders of new nuclear power, particularly in foreign markets.

A nuclear power plant consists of five systems with (at least) three inputs and three outputs; see Figure 1. System-1 consists of the structures that house the equipment. System-2 is the nuclear reactor that converts water or gas and nuclear fuel to steam or hot gas and used fuel with the help of Operation and Maintenance labor and materials. System-3 converts the steam to electric power and condenses the steam with water, or cools the hot gas. System-4 converts the electric power to electricity for the transmission grid, stepping it up to a higher voltage. System-5 releases the excess heat from the cooling system to a heat sink. At nuclear power plants more than two thirds of the cost of delivering megawatt-hours, MWh, to the grid pays for the capital structures and equipment. Compare this to a natural gas Combined Cycle Gas-Turbine, CCGT, where capital represents one-fifth of the cost of producing electricity. The nuclear power plant is capital intensive, although central station solar is even more so.

This implies that the cost of nuclear generated electricity depends crucially on the cost of capital available to the nuclear power plant builder. Thus, the MWh cost estimate depends crucially on the assumed cost-of-capital, which can vary greatly over the different types of owners (public or private), the experience of the owner (incumbent or new entrant), and the jurisdiction (rate-of-return regulated or deregulated). If a national government is the operator, it has access to capital at a lower rate than a privately owned operator, because the probability of default is much lower for governments that can raise taxes. This is important because during construction the interest on loans and the dividends on equity must be paid. If the builder accumulates these payments until the end of construction, the cost of construction is higher than if paid during construction, thus influencing the resulting levelized cost of electricity.

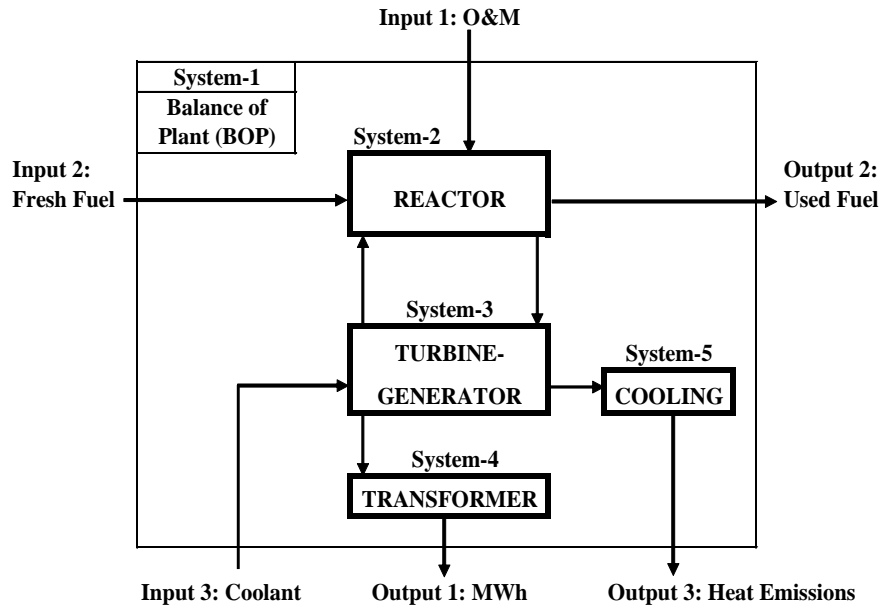
Figure 1: A Generic Nuclear Power Plant (from Rothwell 2012)

Under one type of rate-of-return regulation, Construction Work in Progress, CWIP, used in 26 U.S. states with a combined population of 130 million, the financing expenses can be recovered from customers through tariffs during construction. Under the other type of rate-of-return regulation, Allowance for Funds Used During Construction, AFUDC, used in 9 states with a combined population of 50 million, these financial expenses are not recovered and become a part of the total capital construction cost. In deregulated states (15 states plus the District of Columbia with a combined population of 125 million) tariffs do not necessarily cover the costs of construction or operation, and the nuclear plant investor must shoulder the risk of completion and trouble-free operation. In summary,

40% of the U.S. population lives with CWIP rate-of-return regulation, where there is less financial risk, since regulated utilities can raise tariffs to cover their costs;

20% of the population pays regulated electricity tariffs with AFUDC regulation, where there is little risk of nuclear power plants being built; and

40% of the population pays prices determined in electricity markets, where nuclear investors need loan guarantees to help shoulder the risk of new nuclear power.

What does a large 2-unit new nuclear power plant, for example, AP1000, cost? Unfortunately, there are many answers because there are different ways to express these costs, and there are different assumed costs of capital. The primary difference is whether the cost estimate is in real dollars of a particular year, such as 2007 or 2011, or in mixed nominal dollars over many years, i.e., the addition of dollars spent in 2011 plus dollars spent in 2012, etc., over the period of construction. Economists favor real dollars because the sum is easily converted from one year's dollars to another year's dollars using a deflator, such as the GDP deflator. (This does not escalate cost, which is the purpose of a specific cost index, such as the "Handy Whitman" index.)

For example, in South Carolina Gas & Electric Company's, SCE&G, filings before the South Carolina Public Service Commission are all in real 2007 dollars because that is the year in which the cost estimate submitted to the Commission was done; see SCE&G (2010). Generally, the rule-of-thumb is that inflation is approximately 3% per year, so the real interest rate would be 3% less than the nominal interest rate. However, when there are different tax rates on debt and equity, the real rate is only 1.5% to 2% lower than the nominal rate, see Rothwell (2012, Section 2.4); this difference depends on the tax codes in effect. (When the "risk-free" 90-day U.S. Treasury rate is near 0.0%, the difference between the nominal and real rates is less than 1.5%, including tax effects.)

Another set of differences concerns what to include in the cost estimate. The consensus comparative cost estimate is the "overnight" cost estimate, which is how much something would cost without financing (if done "overnight," not considering the "time value of money," and thus, do not depend on an assumed cost of capital). Other estimates include the cost of transmission construction upgrades to accommodate the new plant. Items outside the plant boundaries ("beyond the bus bar," where the electricity enters the transmission grid) are usually not included, but the debate on this continues. (These costs are not included here.) Finally, there can be differences over indirect costs and owner's costs. Indirect costs are costs that cannot be assigned to one of the five systems in Figure 1, such as the Architect-Engineer-Constructor's project management costs. Owners' costs include licensing fees and the owner's project management expenses (but transmission grid costs are sometimes included in owners' costs, usually doubling the estimate of owners' costs).

All of these differences lead to a wide range of cost estimates for the same project. Unless we parse and compare these accounts, it might appear as if no one really knows how much a new nuclear power plant costs. For example, Rothwell (2012) estimates AP1000a costs to be \$4,400/kilowatt (kW) in 2011 dollars based on estimates for the AP1000s in Table 1. Figure 2 shows the relationship between new nuclear power construction costs and the construction lead time in months. Depending on what is included, the cost estimate can vary between \$4,400/kW to \$6,150/kW, a difference of 40%. Further, the EIA has created confusion by publishing a cost estimate for advanced nuclear power plants based on R.W. Beck, Inc.'s belief system.

Table 2 presents a consultants' estimate of the overnight cost of a kilowatt of nuclear generating capacity, based on the estimate of twin nuclear units with a combined capacity of 2,236 MW, which is the net size of a twin AP1000. While the estimates of structures and equipment are reasonable, capitalized indirect and owners' costs are twice as high as, for example, the rates assumed in TVA's estimate of the cost of an "advanced nuclear" power plant. Therefore, one can adjust the consultant's estimate by using more appropriate indirect and owners' cost adders. (Unfortunately, there are no references in EIA, 2010, making it impossible to guess what the consultants at R.W. Beck, Inc., were thinking when they picked these percentages; one could guess that transmission upgrades were included in owners' costs.) When these adjustments are made (and the contingency rate is *raised* to that in TVA, 2005), the estimate is reduced by \$1,000 per kW, and is almost identical to the assumed cost per kilowatt of new nuclear capacity of \$4,400/kW, when adjusted to 2011 dollars.

Figure 2: Nuclear Power Plant Overnight Cost with Interest During Construction, Inflation, and Real Escalation

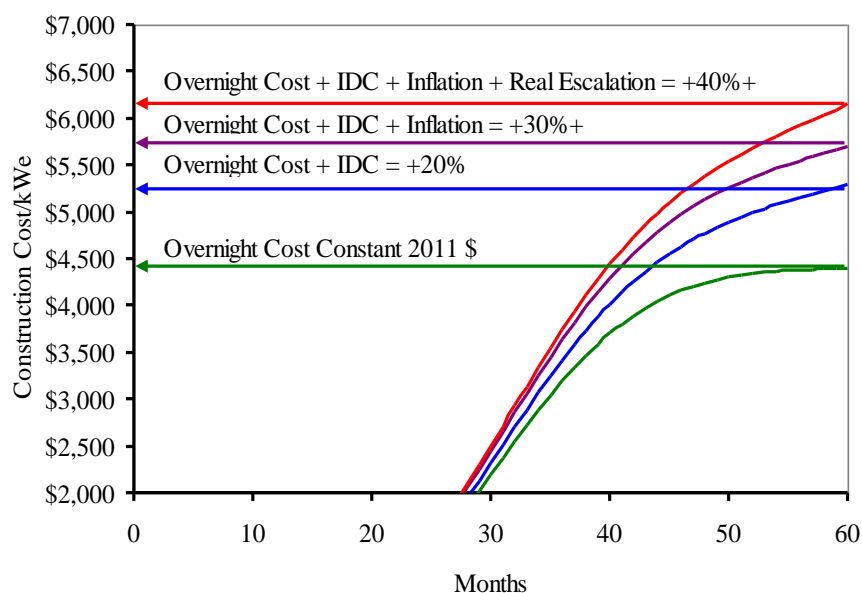

Table 2: Energy Information Administration’s Costs for Advanced Nuclear

Adjusting EIA (2010)		EIA	TVA	Adjust-	Adjusted
Title	M of 2010\$	(2010)	(2005)	ment	EIA (2010)
Structures	\$1,732,000	15%	14%	rounded	\$1,700,000
Equipment	\$4,030,000	34%	52%	rounded	\$4,000,000
Total Capitalized Direct Cost	\$5,762,000	48%	66%	rounded	\$5,700,000
Capitalized Indirect costs	\$2,722,500	23%	9%	= to 9%	\$1,100,000
Capitalized Owners’ costs	\$2,152,590	18%	11%	= to 11%	\$1,300,000
Base Overnight Cost	\$10,637,090	89%	87%	sum	\$8,100,000
Contingency	\$1,300,000	11%	14%	= to 14%	\$1,600,000
Overnight Cost	\$11,937,090	100%	100%	sum	\$9,700,000
Overnight Cost/kWe (2011\$)	\$5,339				\$4,338

To determine the levelized cost of electricity from large and small LWRs, to these costs per kilowatt are added financing costs, or “Interest During Construction,” to arrive at the total capital construction costs. For example, at \$4,400/kW with a real average weighted cost of capital, WACC, of 7.5% (not assuming refinancing at a lower rate at the completion of construction) and a capacity factor of 90% (i.e., over the life of the plant, it would produce 90% of its designed capacity because of outages for refueling and maintenance), the levelized capital costs would be about \$55.43/MWh, including a \$2.22/MWh contribution to a Nuclear Decommissioning Trust Fund, see Table 3, from Rothwell (2012).

Table 3: Levelized Cost for ALWR (e.g., AP1000) Generation (Rothwell 2012)

Levelized Cost	ALWR	FOAK-1	FOAK-5	NOAK
All values in 2011 dollars	r =	7.50%	7.50%	7.50%
Net Electrical Capacity and Unit Size	MW	2236/1118	2236/1118	2236/1118
Cost per kilowatt	\$/kW	\$4,893	\$4,400	\$3,830
Fuel Cost per MWh	\$/MWh	\$6.63	\$6.63	\$6.63
Interim Storage	\$/MWh	\$0.85	\$0.85	\$0.85
Long-Term Disposal	\$/MWh	\$1.00	\$1.00	\$1.00
Levelized Capital Cost + D&D Cost	\$/MWh	\$61.65	\$55.43	\$48.26
Levelized O&M Costs	\$/MWh	\$11.45	\$10.60	\$10.23
Levelized Fuel Cost + Waste Fees	\$/MWh	\$8.48	\$8.48	\$8.48
Levelized Cost	\$/MWh	\$81.57	\$74.52	\$66.97

Other costs include fuel and Operations and Maintenance, O&M, costs. The fuel cost and Back End management costs are about \$8.50/MWh, see Section 3 on the nuclear fuel cycle. O&M costs are approximately \$11/MWh. Here, because of learning, levelized capital and O&M costs decline with the number of plants built. One can assume that the four units being built in China constitute the first four FOAK units, and that the four units being built in the U.S. constitute the second four FOAK units. This implies that future investors in AP1000s can anticipate Nth-of-a-Kind, NOAK, levelized costs of about \$67/MWh. The lower cost is due to (1) the paying off the FOAKE and licensing fees, (2) learning associated with establishing a rhythm of building *8 units*, and (3) access to lower costs of capital because of the fruition of a new technology.

Table 4 presents hypothetical costs for a small LWR based on the recent selection of Babcock & Wilcox's mPower SMR with twin 180 MW reactors. Assuming the same cost of capital and capacity factor, levelized costs for an Nth-of-a-Kind, NOAK (after the construction of *8 plants*, would be about \$87/MWh. These costs are higher because of scale economies in reactor design. Reactor designers have optimized large reactor designs to take advantage of these economies of scale. Small reactor designs have been optimized for transport and modular manufacturing. Given these constraints, their costs are higher per kilowatt of capacity. In addition, fuel costs are higher for the same reason: smaller reactors produce less heat per kilogram of fuel than larger reactors. See discussion of the "scaling law" in NEA (2011, p.17).

On the other hand, small reactors represent a smaller percentage of an electric utility's generating and financial assets. This smaller size could lead to a lower cost of capital required by Wall Street. If the real cost of capital were 5% (which is appropriate for rate-of-return regulated utilities using CWIP rather than waiting until the end of construction), costs would be lower. See Table 5. Thus, at a 5% cost of capital, SMRs could be competitive with larger plants. (Fuel costs are \$0.33/MWh lower because of the capital carrying costs associated with owning nuclear fuel over several years.) However, costs for FOAK plants would be higher and might require some form of government subsidy, for example, in the form of Production Tax Credits or Loan Guarantees, discussed in Section 5.

Table 4: Levelized Cost for SLWR (e.g., mPower) Generation (Rothwell 2012)

Levelized Cost	SLWR	FOAK-1	FOAK-5	NOAK
All values in 2011 dollars	r =	7.5%	7.5%	7.5%
Net Electrical Capacity and Unit Size	MW	360/180	360/180	360/180
Cost per kilowatt of capacity	\$/kW	\$6,700	\$6,000	\$4,900
Fuel Cost per MWh	\$/MWh	\$10.26	\$10.26	\$10.26
Interim Storage	\$/MWh	\$0.85	\$0.85	\$0.85
Long-Term Disposal	\$/MWh	\$1.00	\$1.00	\$1.00
Levelized Capital Cost + D&D Cost	\$/MWh	\$79.58	\$70.54	\$57.84
Levelized O&M Costs	\$/MWh	\$19.67	\$17.77	\$16.96
Levelized Fuel Cost + Waste Fees	\$/MWh	\$12.11	\$12.11	\$12.11
Levelized Cost	\$/MWh	\$111.36	\$100.42	\$86.90

Table 5: Levelized Cost for SLWR (e.g., mPower) Generation (Rothwell 2012)

Levelized Cost	SLWR	FOAK-1	FOAK-5	NOAK
All values in 2011 dollars	r =	5.0%	5.0%	5.0%
Net Electrical Capacity and Unit Size	MW	360/180	360/180	360/180
Cost per kilowatt of capacity	\$/kW	\$6,700	\$6,000	\$4,900
Fuel Cost per MWh	\$/MWh	\$9.93	\$9.93	\$9.93
Interim Storage	\$/MWh	\$0.85	\$0.85	\$0.85
Long-Term Disposal	\$/MWh	\$1	\$1	\$1
Levelized Capital Cost + D&D Cost	\$/MWh	\$56.91	\$50.45	\$41.36
Levelized O&M Costs	\$/MWh	\$19.67	\$17.77	\$16.96
Levelized Fuel Cost + Waste Fees	\$/MWh	\$11.78	\$11.78	\$11.78
Levelized Cost	\$/MWh	\$88.36	\$80.00	\$70.10

In any case, the cost of new nuclear capacity is expensive, but can be competitive with lower costs of capital than in NEMS, in which the EIA assumes that all utilities operate in risky market environments, and, since 2004, has increased the cost of equity capital. The problem with nuclear power in the U.S. is not that nuclear power is too expensive, but that most U.S. electric utilities are too small to undertake an investment that could represent half of their financial assets when the project is completed. What is required are either more joint ventures or smaller nuclear power plants, such as the SMR.

However, we cannot estimate SMR costs precisely until the FOAK engineering is complete, and the NRC has certified a design. The DOE SMR program is providing funds to pay for NRC design certification and for a reference Construction and Operating license, while the industrial partner contributes in-kind engineering. According to the DOE (March 22, 2012),

“Today . . . the White House announced new funding to advance the development of American-made Small Modular Reactors, SMRs, an important element of the President’s energy strategy. A total of \$450 million will be made available to support First-of-a-Kind engineering, design certification, and licensing for up to two SMR designs over five years, subject to congressional appropriations. Manufacturing these reactors domestically will offer

the U.S. important export opportunities, and will advance our competitive edge in the global clean energy race. Small modular reactors, which are approximately one-third the size of current nuclear plants, have compact, scalable designs that are expected to offer a host of safety, construction, and economic benefits.”

Congress appropriated \$67 million in fiscal year 2012, and DOE has requested \$65 million for fiscal year 2013, but appropriations are waiting for Congressional action to avert the next U.S. fiscal crisis, so a budget-cutting Congress could reduce these funds. Table 6 presents a hypothetical deployment scenario for SMRs in the U.S., assuming an electricity price of \$80/MWh, equal to the “Target Market Cost,” assuming 5 years to produce 5.4 GW and 10 years to produce 11.52 GW. These capacities are discussed further in Section 5 as a part of a clean energy scenario with includes 12 more AP1000 units by 2026, another 12 by 2031, and another 12 by 2035.

Table 6: Hypothetical Deployment Scenario for SMRs in the U.S.

Costs and Benefits of SMR Deployment	Stage	R&D	FOAK-1	FOAK-5	NOAK
Anticipated Stage Start Year		2012.0	2016.0	2020.0	2026.5
Average MWh starts at beginning of year	Year	-	2019.5	2024.8	2029.2
Anticipated Stage Completion Year	Year	2016.0	2019.5	2026.0	2035.3
Plants in Stage (2 x 180 MWe)	number	-	1	7	32
Cumulative # of Plants	number	-	1	8	40
Cumulative # of Reactor Modules	number	-	2	16	80
Cumulative Electricity Capacity	GW	-	0.36	2.88	14.4
Millions of MWh/year (<i>CF</i> = 90%)	M MWh	0	2.840	19.881	90.886
Average Total Capital Cost per plant	\$M	-	\$2,736	\$2,425	\$1,989
Total Capital Cost in Stage	\$M	-	\$2,736	\$16,975	\$102,759
Levelized Cost, <i>LC</i>, in \$/MWh	\$/MWh	-	\$88.36	\$80.35	\$70.10
Market Target Cost (= \$ 80/MWh) - <i>LC</i>	\$/MWh	-	-\$8.36	-\$0.35	\$9.90
FOAK Engineering & Licensing	\$M	\$450	\$0	\$0	\$0
PTC (= NOAK - FOAK \$/MWh)	\$M/yr	\$0	\$24	\$7	\$0
PTC (for 15 years, discounted to 2011)	\$M	\$0	\$354	\$88	\$0
Surplus (16 yrs during NOAK Construct)	\$M	\$0	\$0	\$0	\$1,483
Surplus (40 year life, discounted to 2011)	\$M	\$0	\$0	\$0	\$10,854
Costs (M of 2011 \$)	(\$890)	(\$450)	(\$354)	(\$88)	
Benefits - Costs (M of 2011 \$)	\$11,446				\$12,338

This deployment scenario (from Rothwell 2011 based on Rothwell 2007) assumes that the first SMR, most likely a Babcock & Wilcox mPower 360 MW plant at the Clinch River site built by TVA would require a Production Tax Credit subsidy of \$8.36/MWh, which would not be paid until the plant was operating by 2020. This would imply a subsidy of \$354 M over the life of the first SMR. Also, because the average cost for the remaining 7 FOAK plants is \$80.35/MWh (above \$80/MWh for the ninth FOAK plant in Table 5), there could also be a subsidy for these plants as well, equal to approximately \$88 M. These subsidies plus the development costs of \$450 M would imply a cost of almost \$1 B to the U.S. government. On the other hand, if the NOAK units had a levelized cost below \$80/MWh, the U.S. government could charge a licensing fee to recover these expenditures. (In-kind contributions of the SMR developer are recovered as FOAK fees distributed over the first 8 SMR twin-unit plants; see Rothwell, 2012.) Under an arrangement where the FOAK plants were subsidized by Production

Tax Credits, these tax credits would start in 10 years, thus their present value is lower under Office of Management and Budget scoring. If costs are as anticipated for the NOAK units, they should not need U.S. government subsidies. Section 5 discusses this deployment scenario further.

While we will not know the costs of building an SMR for a few years (unlike the Russian and South Koreans who have completed the engineering for their SMRs), we know that their competitiveness will depend on a delicate balance between

- (1) *economies of scale*: small reactors are more expensive per kilowatt because they generate less heat and electricity per dollar spent than a larger reactor,
- (2) *economies of mass production*: the equipment modules and some of the structural pieces will be built in factories by the same teams producing modules year after year, and
- (3) *economies of financing*: because smaller reactors represent a smaller portion of the owner's assets, it should be possible to finance them at a lower cost of capital.

While we learn how these three economies play out, the *final* design certification and licensing of all nuclear power plants has been put on hold for the moment by the NRC as it tries to resolve the “waste confidence” issue, discussed next.

Section 3: Managing Nuclear Fuel

Before dissecting the waste confidence issue, some background is required on the light water reactor nuclear fuel cycle; see Figure 3. There are four sectors in the cycle. The first is the “Front End” from the mining of uranium to the manufacture of the nuclear fuel. The second is the irradiation of the fuel in the reactor. The third is the “Back End” to manage the irradiated nuclear fuel. The fourth is the use of enrichment or reprocessing technology to produce nuclear weapons.

The Front End delivers fuel to the reactor. Uranium consists of two primary isotopes: about 0.72% is U^{235} , which can spontaneously fission when confined in the proper geometry, and about 99.28% is U^{238} , which does not spontaneously fission, but can absorb neutrons from U^{235} fission, transforming into heavier elements, such as plutonium, where Pu^{244} is the most stable isotope of plutonium.

Uranium is mined and milled into an oxide, U_3O_8 , “yellowcake,” and converted to a gas, Uranium Hexafluoride, UF_6 . This gas allows the removal of the heavier U^{238} in the enrichment process, increasing the percentage of the remaining lighter U^{235} . LWRs require Low Enriched Uranium, LEU, with a percentage of U^{235} between 3% and 5%. The enriched UF_6 is converted to a metallic oxide, UO_2 , and pressed into pellets. These pellets are arranged in fuel rods and inserted into the reactor. As an alternative, Heavy Water Reactors, HWRs, can be fueled with natural uranium, eliminating the second step in Figure 3. HWRs are found in Canada (12,604 MW with 18 units), India (4,091 MW with 18 units), South Korea (2,785 MW with 4 units), China (1,300 MW with 2 units), Romania (1,300 MW with 2 units), Argentina (935 MW with 2 units), and Pakistan (125 MW with 1 unit). Plutonium can be recovered from used HWR fuel and reused as LWR, or fast reactor, fuel as India is doing at its GE BWR.

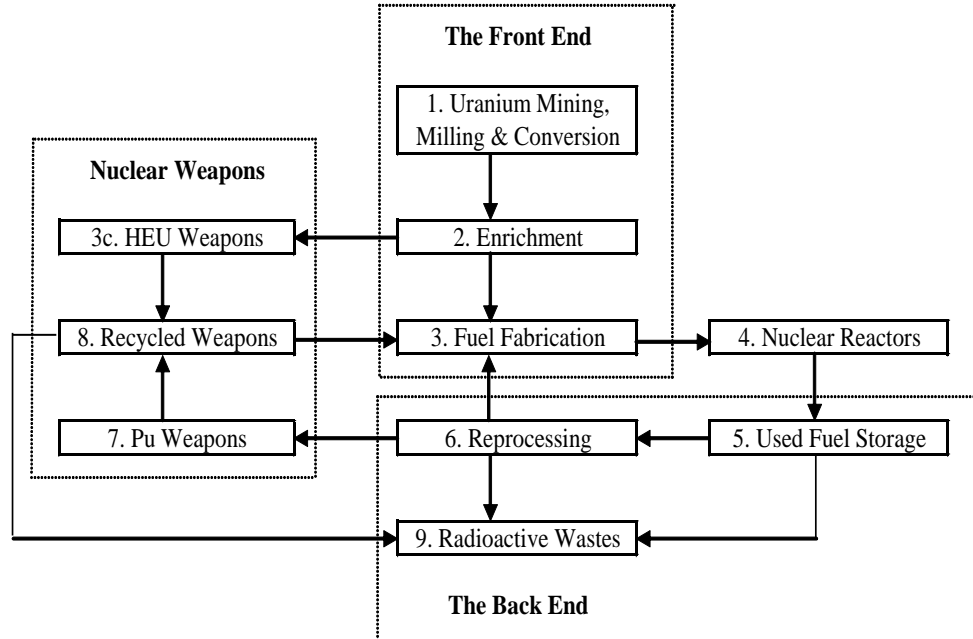
Figure 3: The Light Water Reactor Nuclear Fuel Cycle

After the fuel rods have been rotated in the reactor core over a period of 4 to 5 years, the used fuel is removed, and enters the “Back End” of the nuclear fuel cycle. Instead of 3% to 5% U^{235} and 95% to 97% U^{238} , after irradiation, there is approximately 1% U^{235} , 1% plutonium, 3% other fission products, and about 95% U^{238} . Used fuel can be

- (1) reprocessed into its component elements for re-fabrication into light water reactor fuel (as mixed uranium oxide and plutonium oxide, MOX, as loaded in Fukushima Dai-ichi Unit 3 in August 2010), or
- (2) enter into a waste management system: first, in the fuel pools at the reactor site; second, consolidated at an interim storage facility; and finally, buried in a geologically stable repository, like the one that DOE was going to build into Yucca Mountain outside of Las Vegas, Nevada.

Although there is not a proliferation issue associated with new nuclear power deployment in the U.S., the same technologies used to make nuclear fuel can also be used to make nuclear weapons. A Highly-Enriched Uranium, HEU, device can be produced with a [classified] percentage of U^{235} . Alternatively, irradiated fuel can be reprocessed to extract the plutonium to produce a plutonium device. Neither weapon is easy to make even with the radioactive isotopes required. However, the elements in these weapons can be recycled back into the light water reactor nuclear fuel cycle, as Russia has done with its HEU to feed uranium through USEC to the U.S. nuclear utilities. (Russia used some of its restricted excess enrichment capacity to produce a special blend of UF_6 to mix with its recycled weapons-grade uranium.)

The average 1,000-megawatt nuclear power plant produces 20 metric tons of irradiated fuel per year. Yucca Mountain could have held 4,000 reactor-years of spent fuel (40 years x 100 reactors). (The Yucca Mountain repository was to be licensed to dispose of 80,000 metric tons of

spent fuel, although some geologists believed that it had 50% more storage capacity.) To give some perspective, a 1,000-MW coal-fired power plant with the same output produces about 8,000,000 tonnes of CO₂ per year. The largest Carbon Capture and Storage plant in the U.S. (in West Texas) is expected to be able to store one coal plant's annual CO₂ output. Yucca Mountain would have been the equivalent of 4,000 operating years of the largest U.S. Carbon Capture and Storage plant.

Following the amendments to the *Nuclear Waste Policy Act of 1987*, Yucca Mountain became the only site to be considered in the U.S. for a repository. Five years later the *Energy Policy Act of 1992* directed the Environmental Protection Agency, EPA, to develop standards for a high level nuclear waste repository. After 20 years and over \$10 billion to assess Yucca Mountain as a potential repository, the EPA issued standards, changing the time horizon over which designers had to consider potential radioactive releases from the site to the nearby environment from 10,000 years to 1,000,000 years. Even with these changes, DOE began to develop the license application to the NRC to build a repository at Yucca Mountain. In February 2010, it became apparent that the Obama Administration was discontinuing the funding of the license for Yucca Mountain in its fiscal 2011 budget.

On March 3, 2010, DOE withdrew its Yucca Mountain license application. On March 9, 2010, NRC Commissioner Dale Klein commented,

“Now that one can ask whether the nation is back to square one with regard to the back end of the fuel cycle, the NRC naturally faces the issue of waste confidence . . . What many people—even many people in this room—fail to understand is that the waste confidence rule is a real challenge for us because it is not simply based on the technical judgment of the NRC. Part of the Commission's ‘confidence’ underlying the rule must be based on events that are beyond the NRC's control, and when those events are in flux, the Commission has to be very careful in deciding whether it can credibly say that we have ‘confidence’ that a repository will be open on a given date or period of time.”

On August 7, 2012, the NRC postponed issuance of final Combined Construction and Operating license approvals and license renewal applications (e.g., for Indian Point 2 & 3 with operating licenses expiring in 2014 and 2016) until determining whether it is confident that U.S. nuclear power plants will be able to ship their used fuel away from their sites, allowing them to be decommissioned (taken out of NRC regulatory responsibility), decontaminated, and reused.

To address the issue of DOE's withdrawal of Yucca Mountain, the Blue Ribbon Commission on America's Nuclear Future, the “BRC,” was chartered “to recommend a new strategy for managing the back end of the nuclear fuel cycle.” (BRC, 2012, p. vi) To get the end of the fuel cycle back on track, the BRC proposes six legislative changes (p. viii): (1) establishing a new facility siting process, (2) authorizing consolidated monitored storage facilities, (3) broadening support to jurisdictions affected by spent fuel transportation, (4) establishing a new waste management organization, (5) ensuring access to dedicated funding, and (6) promoting international engagement to support safe and secure waste management. Regarding the authorization of consolidated storage facilities, BRC (2012, p. viii),

“The NWPA [*Nuclear Waste Policy Act*] allows the government to construct one consolidated storage facility with limited capacity, but only after construction of a nuclear waste repository has been licensed. One or more consolidated storage facilities should be established, independent of the schedule for opening a repository. The Act should be modified to allow for a consent-based process to site, license, and construct multiple storage facilities with adequate capacity . . .”

To remedy this situation, Congress can simply vote to strike Section 148(d) of the *Nuclear Waste Policy Act*, PL 97-425, 42 USC 10168:

“(d) LICENSING CONDITIONS—Any license issued by the Commission for a monitored retrievable storage facility under this section shall provide that—

- (1) construction of such facility may not begin until the Commission has issued a license for the construction of a repository under section 115(d);
- (2) construction of such facility or acceptance of spent nuclear fuel or high-level radioactive waste shall be prohibited during such time as the repository license is revoked by the Commission or construction of the repository ceases;
- (3) the quantity of spent nuclear fuel or high-level radioactive waste at the site of such a facility at any one time may not exceed 10,000 metric tons of heavy metal until a repository under this Act first accepts spent nuclear fuel or solidified high-level radioactive waste; and
- (4) the quantity of spent nuclear fuel or high-level radioactive waste at the site of the facility at any one time may not exceed 15,000 metric tons of heavy metal.”

Legislation to unlink interim storage facility development from repository licensing would allow the construction of a privately owned Monitored Retrievable Storage, MRS, facility, such as the one proposed in 2001 by Private Fuel Services, PFS, on Goshute Indian-Skull Valley Band land in Tooele County, Utah; see US NRC (2001). Eight U.S. electric utilities (American Electric Power, Entergy, First Energy, Florida Power & Light, Genoa Fuel Tech, Southern California Edison, Southern Nuclear Company, and Xcel Energy) own PFS, headquartered in La Crosse, Wisconsin. In February 2006, the NRC issued a license to PFS to build and operate (after the licensing of Yucca Mountain) a 40,000 Metric Tonnes of Heavy Metal (MTHM, 4,000-cask, 500-pad) facility for 20 to 40 years, where each cask holds 10 MTHM with a 100 m² footprint inside a 40 hectare storage area on approximately 360 hectares (1.4 square miles).

Based on PFS cost estimates, Rothwell (2012) estimates the levelized cost of a series of “40-year” facilities through 2222 for new nuclear’s used fuel until its eventual disposal or reuse. Assuming a 20-year fuel cooling pool capacity, new nuclear irradiated fuel would begin being transported to such an MRS in 2040 (with new nuclear power plants in 2020). The irradiated fuel could be moved to a new facility in 2080, with the decommissioning of the first MRS in 2100.

Under the 210-year storage plan, irradiated fuel rods flow into and out of a series of facilities. To make levelized cost calculations, the value of the fuel management service was discounted to 2011 using a 3% discount rate following the White House Office of Management and Budget (OMB 1992), guidelines for long-term projects. (This is equivalent of creating a trust fund that would earn a real rate of return of 3% to pay for fuel management expenses until the fuel is disposed.)

Discounted total costs of such a 210-year storage plan are about \$2 billion. A fee of \$0.85 per megawatt-hour, or \$245/kgHM, would pay for these services by 2087. (This is equal to the value in Bunn et al., 2001, based on analysis in Macfarlane, 2001). This is similar to the \$1/MWh contribution to the Nuclear Waste Trust Fund, but could escalate above \$1/MWh given the private ownership of the facility, unlike the present contribution to the Nuclear Waste Trust Fund, which has not inflated since the fund was created in 1982.) Therefore, the resolution of the waste confidence issue, i.e., by building a public or private Monitored Retrievable Storage facility, could double the new nuclear utilities' contributions to the nuclear waste trust fund from \$1/MWh to \$1.85/MWh, increasing the cost of nuclear generated electricity by over 1%.

Section 4: Nuclear Power Plant Safety

Because of the accident at Fukushima in March 2011, public confidence in nuclear safety has once again become an international policy issue. During the over 14,500 reactor-years of worldwide commercial operation, there have been three major accidents at nuclear power plants ($3 / 14,500 = 2 \times 10^{-4}$):

- (1) Three Mile Island, Unit 2 (TMI) a Babcock & Wilcox PWR, in March 1979,
- (2) Chernobyl Unit 4, a Soviet RBMK, in April 1986, and
- (3) Fukushima Dai-ichi Units 1-4, GE-Hitachi-Toshiba BWRs, in March 2011).

The major accidents were caused by equipment failures (due to natural and “man-made” causes) enhanced by miscommunication, mismanagement, and the disabling of the Emergency Core Cooling Systems by plant operators. Three rules summarize the lessons learned from these accidents:

- (1) Design reactors to automatically react to abnormal conditions, and use natural forces, like gravity and thermal convection, to dissipate abnormal levels of heat and pressure: *at the same cost per kilowatt, a passively safe plant is more reliable than an actively safe plant.*
- (2) Have all nuclear power plant and facilities personnel practice “safety culture,” so that safety at all levels is the primary objective; train *all* personnel in emergency operating procedures: *a safer plant is more productive and profitable than a safe plant.*
- (3) Insist on a trustable and trusting, national independent safety regulator that is headed and staffed by knowledgeable experts: *a safer industry with a non-passive regulator is more successful than a safe industry with a passive regulator.*

At 4 am on March 28, 1979, a pump in the cooling system (System-5 in Figure 1) caused a shutdown of the turbine-generator (System-3), which in turn caused a shutdown of the reactor (System-2) at Three Mile Island Unit 2. This automatic shutdown in System-2, or also known as a “scram,” involves the rapid insertion of the control rods into the reactor core to absorb neutrons to stop the chain reaction. Fortunately, inside the reactor building, a valve opened to allow a backup system to absorb excess heat and pressure.

Unfortunately, the valve did not close (letting coolant escape), and the instruments did not alert the operators that the valve was stuck open (the indicator lights showed that the electro-mechanism that closes the valve was on). Because the valve was open, the Emergency Core

Cooling System started within three minutes, but was **turned off** because operators did not understand why it should have been turned on. The sticky valve popped shut within two hours. At 6 am, while the reactor was over heating, during a conference call of the crisis management team, there was no discussion of the faulty valve. By 7 am, the reactor core's fuel began to melt, high radiation levels were detected, and an emergency was declared. Operators re-pressurized the reactor by 8 pm, and it began to cool.

When President Jimmy Carter visited TMI on a gray Sunday morning three days later, he was there to raise hope for an anxious nation. He was not there to intervene, but as an ex-naval nuclear submarine officer, he wanted to show that there was nothing to fear 100 hours after the accident happened. The NRC suspended licensing new plants until after it issued NUREG-0737, Supplement No. 1, *Clarification of TMI Action Plan Requirements: Requirements for Emergency Response Capability* in January 1983. Licensing delays and cost overruns led to the cancellation of dozens of partially completed nuclear power plants by 1984.

In the process, the U.S. nuclear power industry learned that a safe and reliable plant is a productive and profitable plant. Once a nuclear power plant has gone off-line with safety problems, it is difficult and costly to meet NRC requirements to return it to service (e.g., San Onofre Unit 3 is having problems with its steam generators). There have not been any other accidents in the U.S. nuclear power industry for more than 40 years. (There has not been an accident in the U.S. nuclear navy with a small reactor for almost 60 years.)

One of the reasons has been the adoption of "safety culture." While the NRC has always promoted safety, it did not issue a final "safety culture policy statement" until June 14, 2011 (i.e., 3 months after Fukushima):

"The Commission defines Nuclear Safety Culture as the core values and behaviors resulting from a collective commitment by leaders and individuals to emphasize safety over competing goals to ensure protection of people and the environment . . . The accident at the Chernobyl nuclear power plant in 1986, brought attention to the importance of safety culture and the impact that weaknesses in safety culture can have on safety performance. Since then, the importance of a positive safety culture has been demonstrated by a number of significant, high-visibility events worldwide."

At midnight on April 25, 1986, operators begin lowering the power level of their RBMK to conduct low-power tests at Chernobyl Unit 4. By midnight on April 26th, Unit 4 was safely operating at 50% power. The operators **turned off** the Emergency Core Cooling System, the automatic control-rod insertion system, and the alarm system, so these systems would not interfere with the tests. Unfortunately, operators **did not turn on** the system to prevent the power from going below the intended level of the tests. Because of differences in the ability of water and steam to absorb the neutrons liberated during fission reactions, at lower power as the cooling water flashed to steam, more neutrons became available to increase the number of fission reactions, increasing the power of the reactor at an exponential rate. At 1:24 am, a steam (H₂O) explosion destroyed the containment building, and a hydrogen (H₂) explosion ignited Unit 4's graphite and Unit 3's roof. (The heroic efforts of local firefighters saved Unit 3, but 31 eventually died of radiation sickness.) The population within 10 km was evacuated the next day, and the population within 30 km was evacuated the next week and has been excluded ever since.

On May 14, 1986, after 18 days, Mikhail Gorbachev (the General Secretary of the USSR Communist Party from 1985 to 1991), broke his silence on Moscow's nightly news. He denied that there was any cover up of an accident. He argued that the USSR was up against Western public opinion based on "a vast accumulation of lies, unscrupulous and malicious in the extreme" concerning the damages at Chernobyl. On August 20, 1986, USSR officially blamed Chernobyl operators for safety code violations. On February 23, 1989, after 1,018 days, Gorbachev visited Chernobyl with his wife to make sure the plant was safe. With the dissolution of the Soviet Union in 1991, the radiation exposure information evaporated for a half million Soviet Army Reservists who patriotically shoveled chunks of highly contaminated graphite off the Chernobyl site during the spring and summer of 1986.

The magnitude 9.0 earthquake off the coast of Japan, and the accompanying tsunami with the surge of more than 12 meters, hit the Fukushima nuclear power plant on the afternoon of March 11, 2011. All four BWRs operating at Fukushima Dai-ichi (Units 5 & 6 were down for refueling and maintenance), and all four BWRs at Fukushima Dai-ni, 10 km from Dai-ichi, automatically shut themselves down following the earthquake at 2:46 pm. At 3:03 pm, Unit 1's Emergency Core Cooling System was **turned off**.

The second tsunami hit Fukushima at 3:46 pm and cut all electric power to and from Fukushima Dai-ichi, and destroyed 22 of the 23 radiation monitoring stations surrounding the plant. At 6:18 pm, Unit 1's Emergency Core Cooling System was brought back up, but a half hour later Unit 1's fuel began to melt. On March 12th at 3:36 pm during the Japanese Prime Minister, PM, Mr. Naoto Kan's visit, a hydrogen explosion collapsed the roof of Unit 1. On March 14th at 11:01 am, a hydrogen explosion collapsed the roof of Unit 3. At 3 pm, molten MOX fell to the bottom of the Reactor Pressure Vessel, RPV, in Unit 3. On March 15th at 6:10 am and 6:14 am, hydrogen explosions collapsed the roof of Unit 2 and damaged the roof on Unit 4. By 8 pm, molten fuel fell to the bottom of Unit 2's RPV, possibly cracking it. Eventually, TEPCO was able to cool the reactors and announced a cold shutdown on December 16, 2011.

When PM Kan flew around the Fukushima site in a helicopter witnessing the hydrogen explosion in Unit 1 with the plant manager, Mr. Masao Yoshida, on March 12th, he felt like he was a part of the Fukushima crisis management team. Based on this, PM Kan established the Nuclear Emergency Response Headquarters, NER-HQ, in his Cabinet Office with himself as its Director. After an unlucky, cascading series of accidents, missteps, and misstatements, PM Kan resigned six months later. The accident at Fukushima Dai-ichi was a perfect maelstrom churning in the Japanese nuclear power industry for over three years.

Tokyo Electric Power, TEPCO, had denied (until October 12, 2012, see <http://www.youtube.com/watch?v=mFtB96u5CjM>) that it was aware of the possibility that a tsunami of the magnitude that hit Fukushima Dai-ichi on March 11th. (In July 869, *Nihon Sandai Jitsuroku*, compiled in 901, recorded a tsunami of a similar magnitude.) Second, on July 16, 2007, an earthquake caused damages at TEPCO's Kashiwazaki-Kariwa plant (on the east side of the Japanese mainland from Fukushima). These damages included (1) water seal leaks in the reactor core cooling system; (2) oil leaks in the reactor core cooling system pumps; (3) oil leaks in the transformer facility; (4) fires in the transformer facility; (5) loss of power to and from the transformer facility; (6) loss of power to the liquid waste disposal system; (7) cracks in the

cooling water intake system; (8) contaminated water leaks; and (9) uneven liquefaction under the reactor site. Because of TEPCO's inability to get five of the seven units at Kashiwazaki-Kariwa back online (it did bring the two ABWRs back up), it needed to keep Fukushima Dai-ichi in production. Third, in February 2011, the Nuclear Industrial Safety Agency, NISA (a division of the Ministry of Economy, Trade, and Industry, METI), granted a 10-year license extension to the 40-year-old Fukushima Dai-ichi Unit 1, without requiring the annunciation or incorporation of lessons learned from the Kashiwazaki-Kariwa earthquake.

Commissions investigating the causes and consequences of the accident published their findings in December 2011, and in February, June, and July 2012. Aoki and Rothwell (2012) review these reports and summarize their conclusions:

“(1) There were too many micro-interventions by the NER-HQ. As an example, a visit by PM Kan to the site on the morning of March 12, 2011, interfered with the preparation of venting of hydrogen at Unit 1. In addition, NER-HQ's attempts to obtain information directly from the site marginalized the engagement of layers of competent, intermediate bureaucrats.

(2) TEPCO management did not exercise strong leadership during the crisis expected of a “concerned nuclear operator.” For example, between March 14 and 15, 2011, when the risk of a hydrogen explosion of Unit 2 was mounting, they sought the NER-HQ's permission for their personnel to evacuate the site, which NER-HQ rejected. This incident reduced NER-HQ's trust in TEPCO's top management, and the Prime Minister ordered the formation of the Joint Emergency Headquarters within TEPCO's headquarters, directed by the METI Minister and the President of TEPCO. This was seen as an improvement in information flows between the accident site and the headquarters, but the *TEPCO Report* vehemently denies that TEPCO tried to abandon Fukushima.

(3) At the site, Plant Manager Yoshida exercised strong leadership with his dedicated staff laboring in the dark with increasing levels of contamination, while their families struggled with the tsunami's results at their homes. Although they sometimes made mistakes in judgment dealing with the four nuclear reactors having varied vintages and engineering characteristics, they finally succeeded in overcoming the critical situation without proper emergency preparedness and risk-mitigating procedures. For example, on March 12, 2011, Plant Manager Yoshida ordered the continued injection of seawater to cool Unit 1, secretly defying TEPCO headquarters, which was misreading or misunderstanding NER-HQ's apprehensions or hesitations.”

Analysis of these accidents leads to the conclusion that human error must be minimized in nuclear power plant operation. This can be done (1) *by introducing passive safety systems that reduce human intervention*, and (2) *by creating active nuclear safety regulators that intervene sufficiently when necessary*. All U.S. SMRs have passive safety systems, similar to the AP1000. Replacing retiring international nuclear power plants, such as those in Japan, with SMRs makes the nuclear power industry safer. Replacing retiring coal-fired power plants with SMRs makes the atmosphere safer.

Section 5: Nuclear Power under a Clean Energy Standard

How much new nuclear power could be built by 2035? AEO2012, based on the National Energy Modeling System, NEMS, includes about 6.8 GW of new nuclear capacity by 2021, and

no net additions between 2022 and 2035; see Table 7. In contrast, a Clean Energy Standard, CES, case (calculated with NEMS) projects 74 GW (gross) of new nuclear capacity (68 GW net) by 2035; see Table 8.

Table 7 gives AEO2012 results: *new* nuclear capacity grows to 6.8 GW by 2025 and declines by 2035, due to the retirement of more old capacity and the inability of NEMS to forecast the completion of new capacity. AEO2012 results for 2026 are equivalent to the completion of some of the plants in Table 1: Watts Bar 2 at 1.2 GW, Vogtle Units 3 & 4 and Summer 2 & 3 at 2.2 GW apiece, and Bellefonte 1 at 1.2 GW. NEMS forecasts no new (“unplanned”) nuclear power capacity. If the other two plants in Table 1 were completed by 2021, there would be 11.2 GW of new nuclear power capacity. If the utilities that have applied for Combined Construction and Operating Licenses, COLs, complete their four AP1000s by 2026 at William Lee Harris Units 1 & 2 in South Carolina and Shearon Harris Units 2 & 3 in North Carolina (states with rate-of-return regulation with CWIP accounting) by 2026, there would be another 4.4 GW of capacity.

Table 7: AEO2012 Final Release Using NEMS

NEMS Forecast Year	2011	2016	2021	2026	2031	2035
Total U.S. Nuclear Power Capacity	101.4	106.3	111.7	114.7	113.2	109.9
Cumulative “Planned” Additions	0.0	3.3	6.8	6.8	6.8	6.8
Cumulative “Unplanned” Additions	0.0	0.0	0.0	0.0	0.0	0.7
Cumulative “Planned” Retirements	0.0	0.0	0.6	0.6	2.1	6.1
Net changes from previous period	0.0	3.3	5.4	3.0	-1.5	-3.3

Table 8: A Clean Energy Standard Forecast in NEMS

NEMS Forecast Year	2011	2016	2021	2026	2031	2035
Total U.S. Nuclear Power Capacity	101.4	106.3	116.9	132.0	152.0	170.0
Cumulative “Planned” Additions	0	3.3	6.8	6.8	6.8	6.8
Cumulative “Unplanned” ALWRs	0	0	4.84	14.42	28.96	47.7
Cumulative “Unplanned” ALWR units	0	0	4	12	24	40
Cumulative “Unplanned” SMRs	0	0	0.36	2.88	8.64	14.4
Cumulative “Unplanned” SMR plants	0	0	1	8	24	40
Cumulative “Unplanned” Additions	0	0	5.2	17.3	38.8	60.9
Cumulative “Planned” Retirements	0	0	-0.6	-0.6	-2.1	-6.1
Net Nuclear Capacity Changes	0	3.3	11.4	23.5	43.5	61.6
Net change from 2011	0	4.9	15.5	30.6	50.6	68.6

Further, if those utilities that applied for COLs in 2007 and 2008 converted their applications to AP1000s, this would yield another 8 units, or approximately 9 GW. This would most likely require some form of subsidization as provided for in the *Energy Policy Act of 2005*. Once these plants have been built, the cost of capital would be lower for later plants, encouraging the construction of more large units. Further, following the scenario for SMR deployment in Table 6, SMR capacity has been subtracted from total “unplanned” (forecast) additions, yielding the number of required larger units. The required number of units would be 4 by 2021, 8 more by

2026, 12 more by 2031, and 16 more by 2035. This will likely require some U.S. federal encouragement.

Why are the AEO base and the Clean Energy Standard cases so different? One of the major problems with NEMS is that it assumes *all* electricity-generating plants are being built in a deregulated (merchant) environment. As discussed in Rothwell (2010, p. 39), the cost of capital for nuclear power plant investment in the NEMS is assumed to be about 17% return-on-equity and 8%+ interest on debt. To determine the discount rate (equal to the Weighted Average Cost of Capital, WACC), EIA (2011, Appendix 3.D, “Cost of Capital,” p. 90-96) describes how WACC is determined in NEMS for *all* electric utility investments in the Electricity Capacity Planning, ECP, sub-processor:

“The ECP chooses the mix of plants that will minimize the total system costs of meeting consumers’ electricity needs. The model performs a discounted cash flow analysis of the costs of building and operating power plants over 30 years and chooses the least cost mix of options. *The ECP assumes that building power plants will take place in a competitive environment rather than in a rate base or regulated environment.* Each year, the assumptions and parameters for discount rates and the weighted average cost of capital (WACC) are reviewed to reflect the changing nature of the power industry and to incorporate new capital market information. For example, *since the AEO2004, the EIA has increased the equity portion of project financing and the return required on equity to reflect the greater risk associated with investments in a deregulated market.* The discount rate (WACC) is a very important component because the rate reflects the riskiness of the investment and affects the mix of capacity additions. For instance, [the figure] shows the sensitivity of unplanned capacity additions to discount rates; *small changes in the weighted average cost of capital lead to huge changes in capital intensive capacity additions.*” (*emphasis added*)

Therefore, encouraging nuclear power plant construction in the U.S. and in NEMS to achieve clean emissions standards should focus on reducing the cost of capital and the risks of building new nuclear. Reducing the cost of capital is the responsibility of the builder (with shorter construction times), the owner (by diversifying generation assets), the operator (with high safety and reliability), the federal government (by creating programs similar to those in the *Energy Policy Act of 2005* to overcome capital market failures), and Wall Street (through becoming familiar with nuclear technology). With these forces aligned, in the next two decades, the U.S. could build an SMR manufacturing industry on a foundation of the world’s most successful nuclear navy, replace retiring nuclear plants in the U.S. with large and small passively-safe reactors, and provide a basis for reducing green house gas emissions.

References

- Aoki and Rothwell. 2012. “A Comparative Institutional Analysis of the Fukushima Nuclear Disaster: Lessons and Policy Implications,” *Energy Policy*.
- Bunn, M., Holdren, J., Macfarlane, A., Pickett, S., Suzuki, A., Suzuki, T., and Weeks, J. 2001. *Interim Storage of Spent Nuclear Fuel*, Harvard University and University of Tokyo.
- Macfarlane, A. 2001. “The problem of used nuclear fuel: lessons for interim solutions from a comparative cost analysis,” *Energy Policy* 29: 1379–1389.

- Moody's. 2007. *New Nuclear Generation in the United States: Keeping Options Open vs. Addressing An Inevitable Necessity* (October). New York, NY: Moody's Investor Services.
- Moody's. 2008. *New Nuclear Generating Capacity: Potential Credit Implications for U.S. Investor Owned Utilities* (May). New York, NY: Moody's Investor Services.
- Moody's. 2009. *Special Comment: New Nuclear Generation Ratings Pressure Increasing*. (June). New York, NY: Moody's Investor Services.
- Moody's. 2011. "Moody's downgrades the senior unsecured rating of SCANA to Baa3 and the senior unsecured rating of South Carolina Electric and Gas to Baa2; Outlooks revised to Stable." (15 September). New York, NY: Moody's Investor Services.
- NEA (Nuclear Energy Agency). 2011. *Current Status, Technical Feasibility and Economics of Small Nuclear Reactors*. OECD (June).
- Office of Management and Budget (OMB). 1992. *Guidelines and Discount Rates for Benefit-Cost Analysis of Federal Projects*, Circular No. A-94 Revised (29 October).
- Rothwell, G.S. 2007. "Managing Advanced Technology System Deployment: An Optimal Allocation between R&D and Prototype Funding," *Economics of Innovation and New Technology* 16(6): 419-432.
- Rothwell, G.S. 2010. *New U.S. Nuclear Generation: 2010-2030*, Resources for the Future Reports, Washington, DC (June).
- Rothwell, G.S. 2011. *The Economics of Future Nuclear Power: An update of the University of Chicago's 'The Economic Future of Nuclear Power,'* Argonne National Laboratory with the U.S. Department of Energy (March 17).
- Rothwell, G.S. 2012. *New Nuclear Power Economics*, Department of Economics, Stanford University.
- SCE&G (South Carolina Electric & Gas Company). 2010. "Chart A: Reconciliation of Capital Cost," *Quarterly Report to the South Carolina Office of Regulatory Staff, Pursuant to Public Service Commission Order No. 2009-104(A)*, Sept. 30, 2010.
- TVA (Tennessee Valley Authority). 2005. *ABWR Cost/Schedule/COL Project at TVA's Bellefonte Site*. U.S. Department of Energy Contract DE-AI07-04ID14620. TVA, Knoxville, TN.
- U.S. EIA (Energy Information Administration). 2010. *Updated Capital Cost Estimates for Electricity Generation Plants* (November) Washington, DC: EIA
- U.S. EIA (Energy Information Administration). 2011. *The Electricity Market Module of the National Energy Modeling System: Model Documentation Report*. DOE-EIA-M068(2011) (July). Washington, DC: EIA.
- U.S. EIA (Energy Information Administration). 2012. *Annual Energy Outlook 2012*. Washington, DC: EIA.
- U.S. NRC (Nuclear Regulatory Commission). 1983. *Clarification of TMI Action Plan Requirements: Requirements for Emergency Response Capability*. NUREG-0737, Supplement No. 1 (January)
- White House Office of the Press Secretary. 2010. "Obama Administration Announces Loan Guarantee to Construct New Nuclear Power Reactors in Georgia." Washington. (February 16, 2010). Washington, DC.